



PATHFINDER® A2

Designed in Germany



Applications

- Airport
- Station
- Office Complex
- Shopping Mall
- Hotel
- Hospital
- Cinema Hall
- Convention Hall
- Exhibition Hall
- Sports Stadium
- Apartment Complex

Operating Specifications

Input Voltage	: 190 V - 265 V AC
Battery	: Self-contained Ni Cd Battery
Battery Back-up	: 3 Hours
Frequency	: 50/60 Hz
Colour Temperatures	: 6000 K
Optics	: Acrylic Diffuser
Average Luminance (White):	≥ 500 cd/m ²

Indication of Battery and Self Diagnostics Status

Function test	Weekly 5 minutes test duration	
Duration test	The 52 nd function test is a duration test of 3 hours	
Green continuously	Mains available, Charging OK	
Off	No mains available or emergency mode	
Red flashing (1Hz)	Lamp source faulty	
Red continuously	Battery failure	
TEST Red / Green alternating	Test mode	

PATHFINDER®
Designed in Germany

Emergency Exit Signage

Essential Features

• Ingress Protection 20		
• Standard Automatic Self Test		
• Suitable for mounting on either a ceiling or a wall by simply changing the end caps		
• Safety Standard : EN 60598		
• Emergency Lighting Standard : EN1838 /CIE S 020 (2007)		
Electromagnetic Compatibility EMC Standard	EN 61547 for EMC Immunity	EN 55015 for Disturbance Measurement
Electromagnetic Compatibility is essential to prevent Electromagnetic Interference which disturbs the operation of Mobile Phones, Pacemakers, Internet Operation and can cause data loss.		

Product Code	Product Name	Size (mm) (L x B x H)	Input Power	Viewing Distance (m)	Weight (Kg)
GS 01 32	Pathfinder A2	320 x 45 x 205	8 Watts	32	1.36

Specifications subject to change

Mounting Options

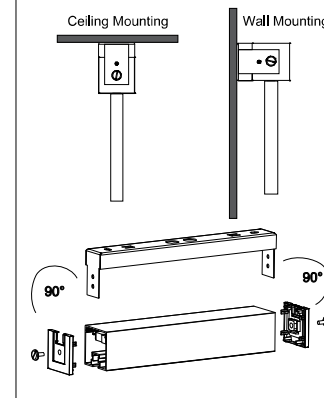

Dimension Drawing

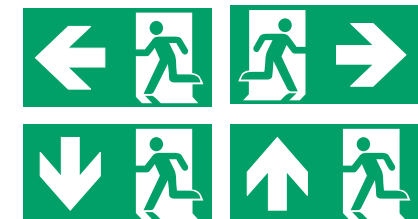
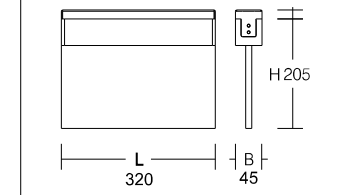

4 Different Pictograms for Exit Signage